

Assembly of Ogawa Sampler

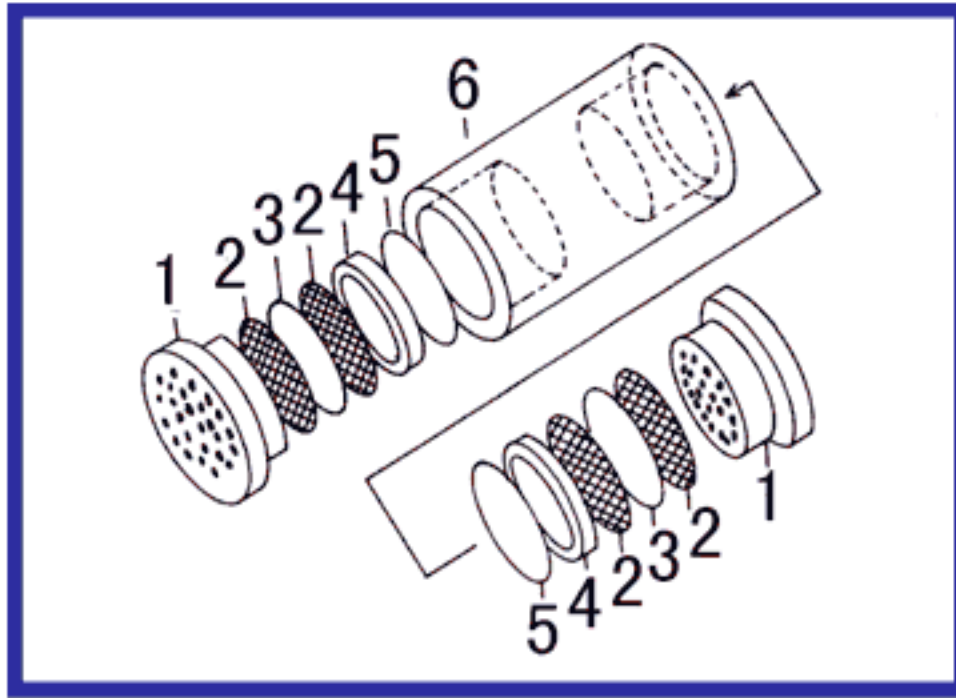

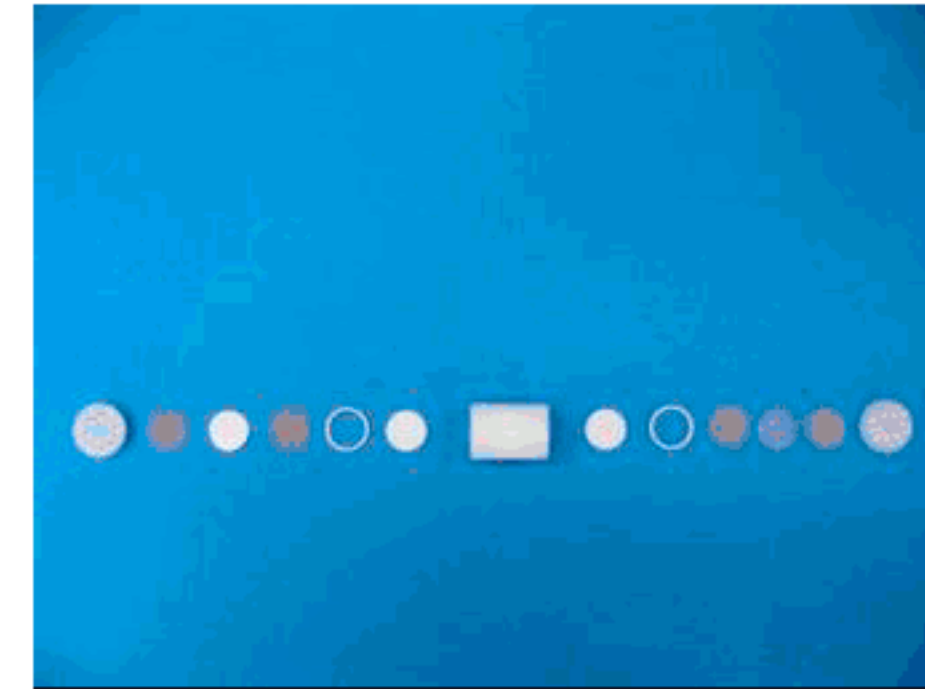



All sampler components should be carefully rinsed with pure water and dried before each use.
The sampler is comprised of 2 identical chambers. Each of which is assembled as is described below.



1. Diffuser End Cap
2. Stainless Screen
3. Collection Pad (14.5mm)
4. Teflon Ring
5. Teflon Disk
6. Body

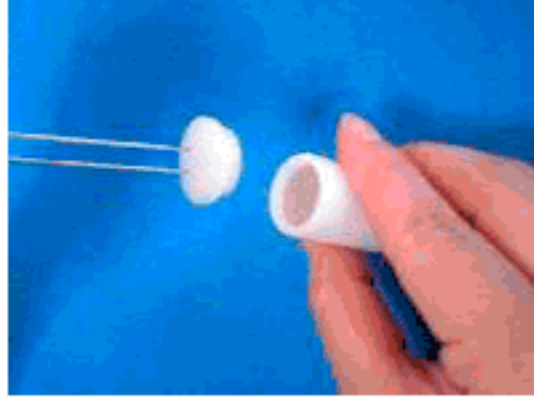

Start at the inner-most position with the Teflon disk and progress outwards to the diffuser end cap

- 1** Place Teflon disk into innermost position. 
- 2** Place Teflon ring on the disk. 
- 3** Place stainless screen on the ring. 
- 4** Place collection pad on the screen. 
- 5** Place second screen on the collection pad. 
- 6** Insert end-cap and press to secure. 
- 7** Slide the sampler into the sampler clip. 
- 8** Place sampler into brown screw-top vial and close securely. 

ASSEMBLY should be done using pincers for touching all internal parts of sampler
ASSEMBLY should be done in a clean area