

High-Quality Passive Sampling of NO-NO_x, NO₂, SO₂, O₃ and NH₃ in Indoor or Outdoor Environments

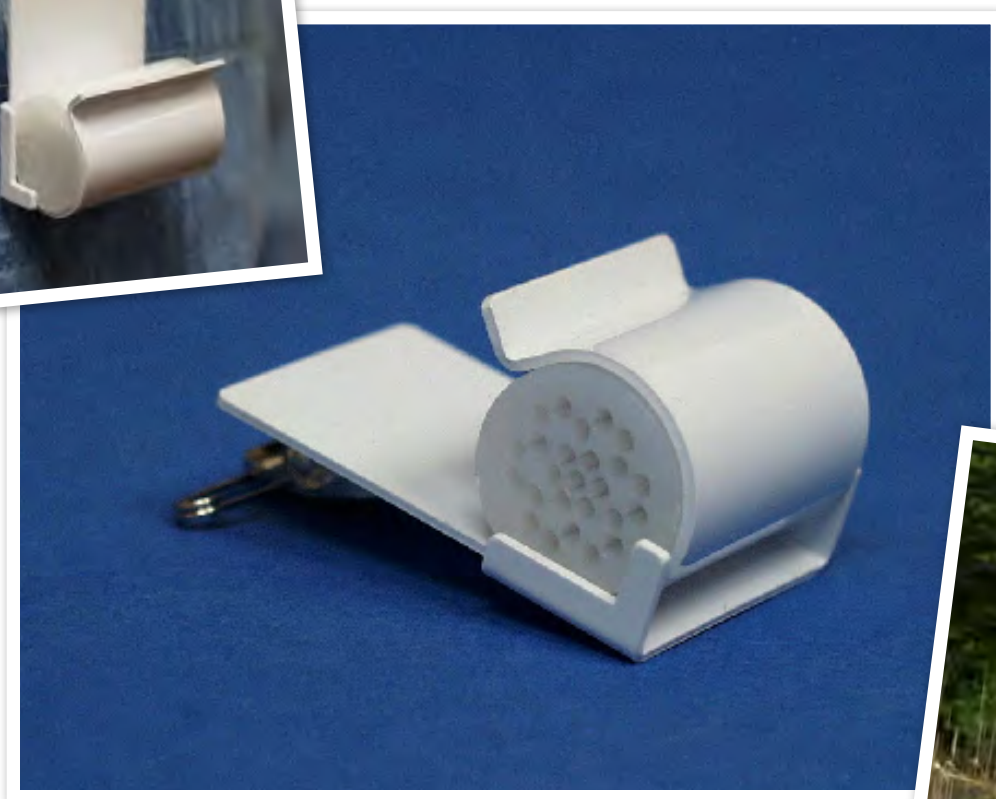

1230 S.E. 7th Avenue • Pompano Beach, FL 33060 • USA
Phone +1 (954) 781-6223 • Fax +1 (954) 781-6224
E-Mail sales@ogawausa.com
Web www.ogawausa.com

Passive Sampling for a Range of Applications

The Ogawa Passive Sampler is manufactured and distributed worldwide by Ogawa & Company, USA, Inc. The sampler has seen use in a large number of air monitoring campaigns as well as specialized applications in indoor and outdoor environments. The system is currently available for the determination of NO, NO₂, NO_x, SO₂ and O₃ concentrations, with additional components planned for the future.

Key features of the sampler have been patented by Ogawa as the result of extensive field measurements to optimize performance. Extensive characterization by organizations such as the USEPA and the Harvard School of Public Health have shown excellent comparability between results from the Ogawa Passive Sampler and averaged measurements from continuous gas analyzers.

The system's low cost and lack of power requirements makes it the ideal tool for determining the concentration of selected ambient gases at desired sampling locations. It can provide an effective means of determining the gradients in pollutant levels across an urban and/ or background area through "saturation" sampling at many sites. One longtime user in the US has been the National Park Service. It can be used as a personal sampler to assess the average exposure of individuals to selected pollutants over an 8- or 24-hour period.

Archives, national libraries and art museums employ the Ogawa Passive Sampler to track the levels of gaseous pollutants over time to protect their holdings.

The implementation of the sampler does not require highly skilled personnel, making it feasible to establish even large air sampling networks with minimal training without the need for conventional analyzer maintenance.



Ogawa Passive Sampler located at outdoor location in Standard Shelter, showing mounting components.

Sampling Configurations

The Ogawa Passive Sampler is composed of a plastic body with an air inlet on either side. It is possible to sample more than one gas simultaneously, since the two inlets are separated by the solid section of the body. The dual-sided body is usually mounted on a clip that can be fastened to a person or installed in a protective outdoor shelter (see photos).

The shelter is required for outdoor sampling.

Operating Principle

The Ogawa Passive Sampler contains two gas collection pads in its dual-inlet configuration. The pads are 14.5 mm in diameter, and are specially coated to react chemically with a selected gas or gases. Analysis of the collection pads takes place in a laboratory using routine analytical procedures to determine the average gas concentration level during pad exposure. Standard operating procedures for performing analyses are available from the Ogawa & Co., USA, Inc. worldwide web site (www.ogawausa.com)

The construction of the chamber in which the collection pad resides is carefully engineered to ensure representative sampling. Following the Ogawa patented inlet (diffusion barrier), the collection pad is sandwiched between two stainless steel screens. Behind the screens, a ring and backing tab maintain the desired ventilation conditions.



Sampler components (left to right): Body (6), Backing Tab (5), Ring (4), Stainless Steel Screens (2), Collection Pad (3), and Inlet (1).

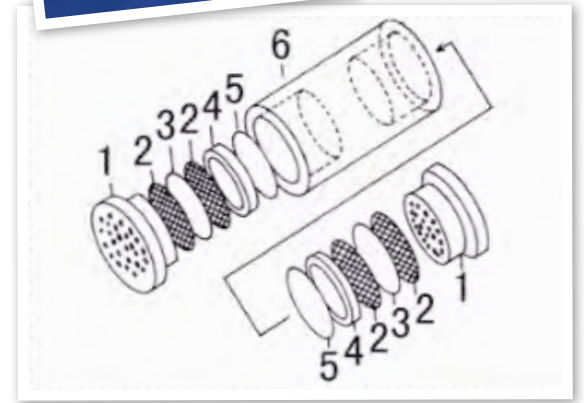

Sampling Procedure

The components in the Ogawa Passive Sampler, including the pad, are prepared in a laboratory or staging area. Collection pads are packaged 40 per bottle, and are easily installed using tweezers (see photos). Refrigeration is *not* necessary between the preparation of the sampler and its implementation in the field.

Samples are generally taken over periods of one day to two weeks, but substantially shorter or longer periods are achievable in higher or lower concentration environments.

Following exposure, the samplers and/or pads are returned to the laboratory for analysis. A variety of containers are available, depending upon whether the sampler with clip, sampler body, or only the collection pad is to be transported.



Bottle of 40 Collection Pads



Insertion and removal of Collection Pads is performed using tweezers.



Container for Sampler in Clip, housed in plastic bag.



Container for exposed Collection Pad.



Insertion of exposed pad into Small Shipping Vial.

Control samplers are necessary for accurate results

A 'control' sampler with a pre-coated pad from same batch as field samplers is required for accurate results. The control sampler should be kept in the brown vial – not exposed.

A batch of samplers consists of a group of field controls (unexposed control sampler) and field samples (exposed samplers), which share the same coating date, the same preparation date, the same handling, and preferably, the same analysis date. Since unexposed pre-coated filter pads are stored refrigerated before being loaded into samplers, all pads used for a designated batch must be removed from the refrigerated vial at the same time. Pads should be removed from the refrigerator about 12 hours before exposure for the purpose of equilibrating to the room temperatures. This is done to prevent condensation from forming on the pad. Moisture is the enemy of the coated pad, as it can remove some of the collecting material.

Samplers from the same batch are assembled, exposed, and disassembled over some period of time defined by the field study, but for the best results, the time period should not exceed four weeks. The control and field samplers are kept together except when the field samplers are actively collecting air gases. The control sampler should be kept in the brown vial (not exposed). As much as is possible, keep all the control and field samplers at the same approximate locations and temperature. When the sampling is completed, place the exposed samplers in the brown vial in a cool place, until they are ready to prepare for analysis. This will minimize variation in the differences due to temperature effects within the batch. Remove the exposed field pads and control unexposed pads from the samplers in a clean environment. It is best to do the analysis as soon as possible, but can be done within 2-3 weeks after exposure.

When the exposed pads and control unexposed pads are sent to a lab to be analyzed, the field controls are considered samples and clients will be billed for analysis of field controls.

Further Instructions for filling out COC (Chain of Custody) Form that is to be sent to the lab with the exposed pads can be found on the Ogawa website, www.ogawausa.com, under the tab 'Analysis Instructions/Form'.



1230 S.E. 7th Avenue • Pompano Beach, FL 33060 • USA
Phone +1 (954) 781-6223 • Fax +1 (954) 781-6224
E-Mail sales@ogawausa.com
Web www.ogawausa.com

Comparative Results

The USEPA conducted a study of the ambient ozone (O_3) concentration in the Dallas, Texas, area with Ogawa Passive Samplers at 34 sites, with continuous monitors co-located at four sites. The POND (Passive Ozone Network in Dallas) study ran from 13 July through 3 September 1998. Many of the passive samples were collected by volunteers from service organizations such as 4-H Clubs and Master Gardeners, and by farm retirees.

At the four sites where the USEPA co-located Ogawa Passive Samplers with continuous ozone monitors, the coefficient of determination, r^2 , with the continuous monitors ranged between 0.90 and 0.97. The graph for the Keller site (shown below) exhibits a value of 0.948 for 24-hour ozone averages.

The USEPA also examined the precision of co-located 24-hour results from passive ozone samplers as part of the POND study. This involved 912 pairs of replicate samples. The median difference in the measured ozone concentration was 1.38 ppb, with 90% of the precision comparisons falling within 3.83 ppb of each other.

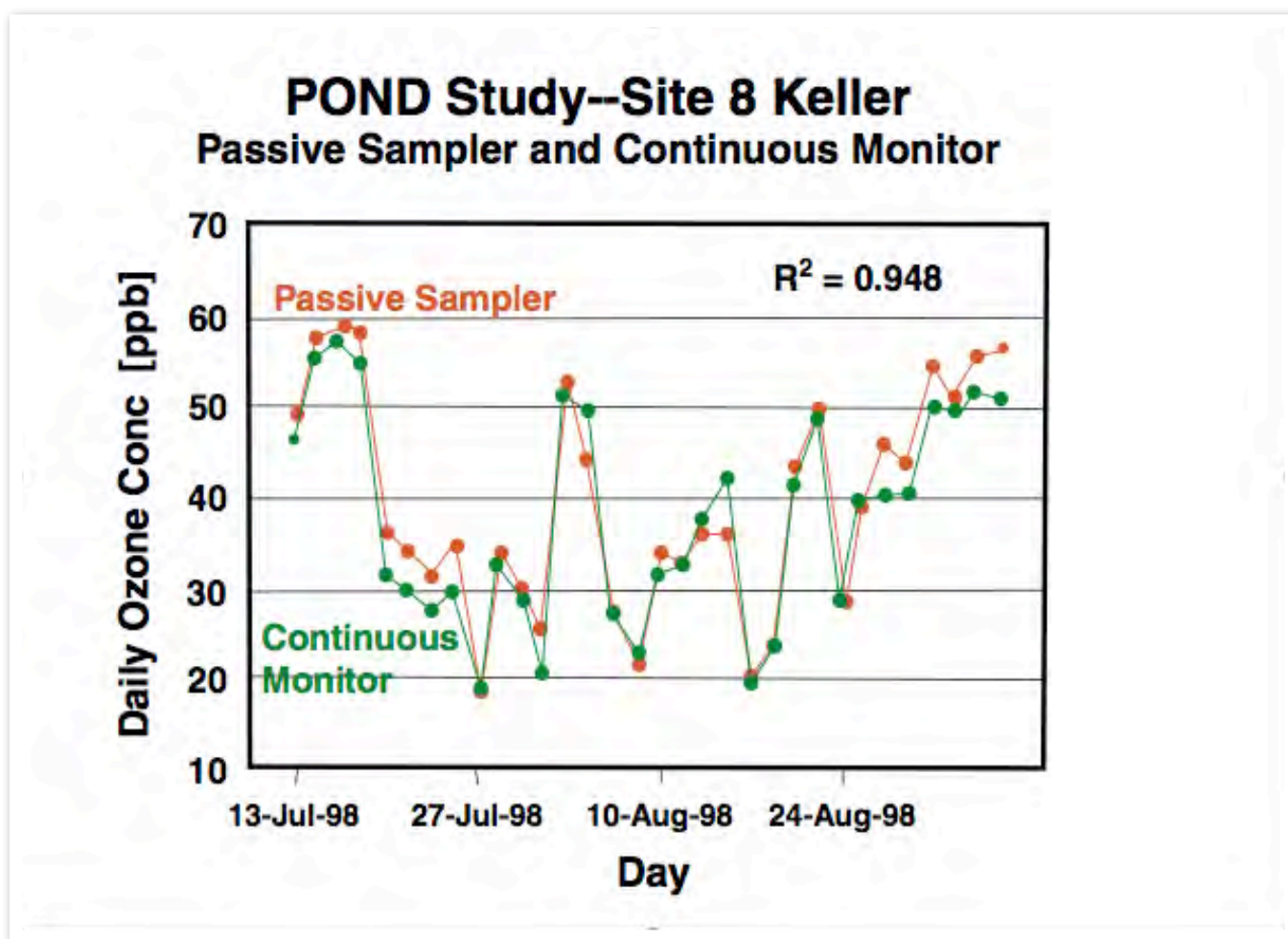

Source of USEPA Results: Poster paper entitled "The Passive Ozone Network in Dallas (POND Concept) - a Modeling Opportunity with Community Involvement." co-authored by Jerry L. Varns and James D. Mulik, NERL/RTP, NC, USEPA. Presented at 31st Annual Air Pollution Workshop, Corvallis, OR, April 26-29, 1999.