

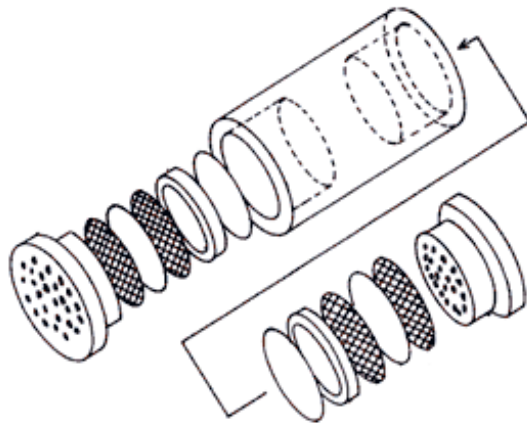

NH₃

Sampling Protocol

Using The Ogawa Sampler*



Yokohama City Research Institute for Environmental Science
1-2-15, Takigashira, Isogo-ku, Yokohama, 235-0012 Japan

Notice

Certain products mentioned in this User's Guide may be trademarks. These products have been mentioned for identification purposes only.

Version Number

| Edition | Month / Year |
|----------------|---------------------|
| 1.0 | September / 2005 |
| 2.0 | October / 2010 |

General Information

1. "Water", in all cases, shall mean water meeting ASTM Type I specifications. (Equal to Milli-Q by Millipore). Use Reagent grade chemicals for all applications.
2. "Wash", in all cases, shall mean cleaning thoroughly with water meeting ASTM Type I specifications.
3. All sampler components should be carefully washed and dried before each use. This is an important function, and special care should be taken to do this step carefully.
4. Washing, drying, assembly of sampler, and loading with the proper pre-coated filters should be done in a clean area, free of NH₃ contamination. It is not necessary to use a glove box.
5. When the point of research is outdoors, the sampler should be given protection from the sun and rainfall. Ogawa & Co., USA, Inc. has an opaque shelter and mounting bracket designed for that purpose.
6. Direct exposure of individuals can be easily measured by using the alligator clip to attach the sampler to clothing as close to the face as possible.

Ogawa Sampler Assembly

The sampler is comprised of 2 chambers. In each chamber of the sampler, the assembly stack-up is described below. Start at the innermost position with the pad and progress outwards to the diffuser end cap.

1. Solid Pad
2. Pad Retaining Ring
3. Stainless Screen
4. Coated Collection Filter
5. Stainless Screen
6. Diffuser End Cap

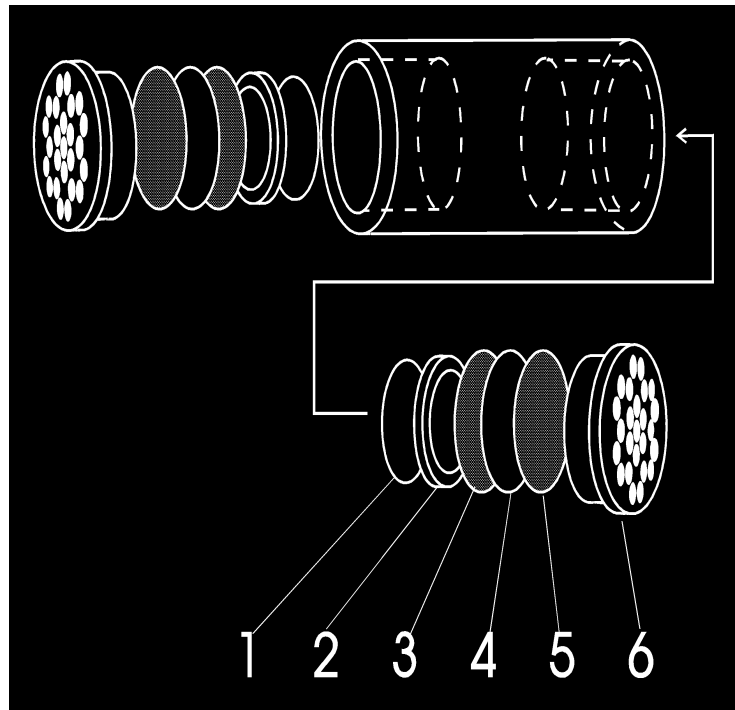

Transport and Storage

After assembly, the loaded sampler is placed into the re-sealable plastic bag. The bagged sampler is placed into the brown airtight container, provided, and taken to the exposure site. After exposure, the above procedure is again followed to safely seal the used sampler into the brown airtight vial. It is then taken to the laboratory for analysis.

The sampler has the following lifetime associated with the various components:

| | Refrigerated Storage Method | Frozen Storage Method |
|--|--|--------------------------------------|
| Sealed in glass vial and aluminum pouch | 90 days | 1 year |
| Resealed in vial, after opening | 90 days | |
| Loaded sampler in bag placed in brown vial with lid | 90 days | |
| Exposed loaded sampler, in bag placed in brown vial with lid | 14 days | |

Table 1: Shelf life associated with Passive Sampler Components.

Application of the Sampler in an Outdoor Micro-Environment

It is mandatory to protect the loaded sampler from moisture while it is being exposed. To accomplish this task, and still retain proper airflow to the device, it is necessary to use P/N PS-115 Opaque Shelter w/sampler bracket, which is shown on our price list as being for NO-NO_x, NO₂, and SO₂.

The PS-115 mounting bracket is attached to the site using several small screws or by passing a wire through two holes on each side of the bracket and then around the pole or post.

The sampler easily clips on to the bracket and the cup slides over the bracket to protect the sampler.

The PS-106 sampler bracket, once the sampler is clipped to it, easily slips over the shelter to hold the sampler in the correct position within the shelter.

NH₃ Analytical Procedure using Ogawa Sampler

Preparing of the NH₄ Standard Solution

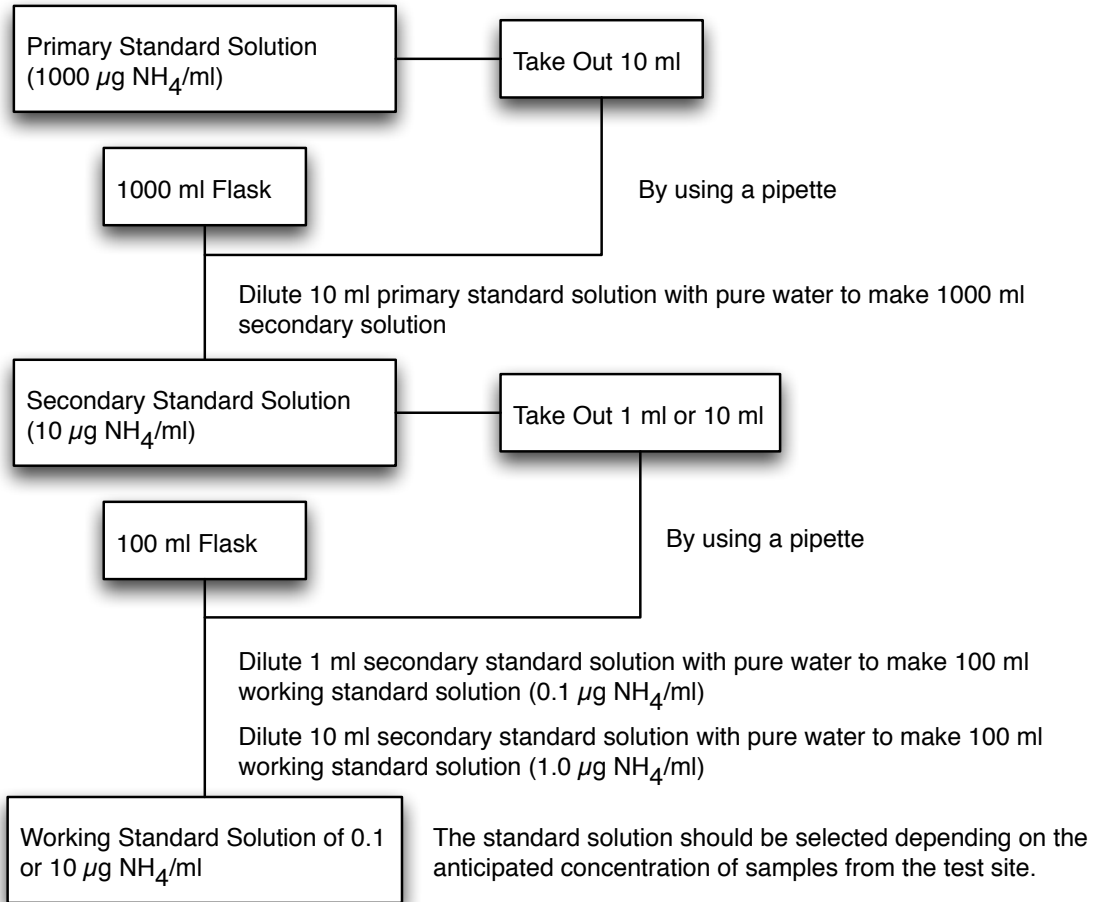

Analytical Procedure of NH₃

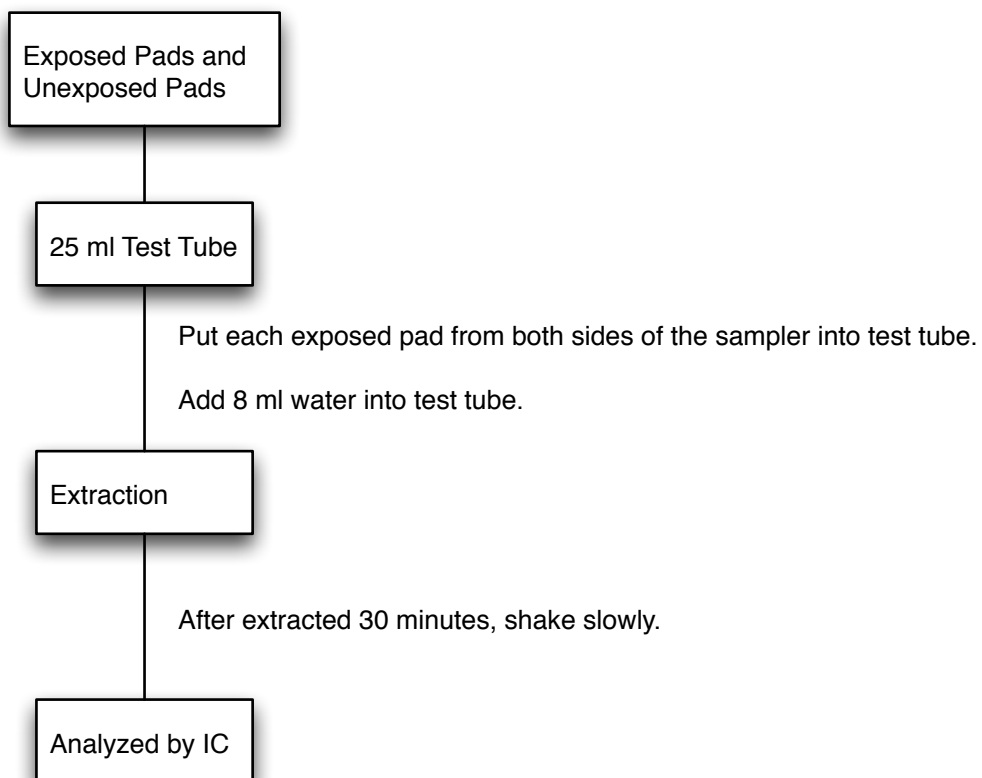

Calculation for NH₃ Concentration

